



# TC-1000 Solid State Timer/Counter

The TC-1000 Solid State Timer/Counter is a microprocessor based multi-use controller dedicated to the operation of centralized lubrication systems.

The TC-1000 schedules lube frequency either on a time or stroke/cycle basis in values ranging from 1-9999. The pump run interval is also selectable in time or counts over the same range.

The TC-1000 is easily programmed in the field using four mini push-buttons. No special training or knowledge of computer language is necessary. During power down or outage, data is saved in EEPROM (Electrically Erasable Programmable Read Only Memory). When power is restored, counting and pump status is restored to values prior to loss of power.

Available for 115 VAC, 230 VAC, 12 VDC, or 24 VDC operation. Pump Output voltage is the same as supply voltage.

## SPECIFICATION

### Power Supply

- 115 VAC ± 10%, 50 or 60 hz, 1ph
- 230 VAC ± 10%, 50 or 60 hz, 1ph
- 12 VDC ± 10%
- 24 VDC ± 10%

### Output Voltage (Same as Supply)

- 10 A Relay Output (External Fused by User)
- 1/3 HP Inductive Load

### Temperature Range

- Operating ..... -20°C to 50°C (-4°F to 122°F)
- Storage ..... -25°C to 60°C (-13°F to 140°F)

### Enclosure

High impact plastic

### Programming Selection

Hours, Minutes, Seconds, Counts

- On Time: ..... 1 to 9999 (Program for 5 -15 seconds for piston distributor applications)
- Off Time: ..... 1 to 9999

### Stroke/Cycle Input

- Input Rate: 10 Hz (600 CPM)
- 24 Volts (Internally Supplied)
- Selectable for either Source or Sink
- Solid State Proximity Switch or Dry Contact

### Other Inputs

- 12 Volts, Dry Contact, 2.5 mA Max.
- Manual Run
- Jog
- Enable



### Display

- Supertwist LCD
- Annotated 4 Digit

### Program Entry

- 4 Mini Push Buttons - Program, Increase, Shift, Enter

### Manual Run

- Press Manual Run to Start a Full Lube Cycle
- Simultaneously Press Select & Enter for "Jog" & Cancel Lube Cycle

## DIMENSIONS mm/(Inches)

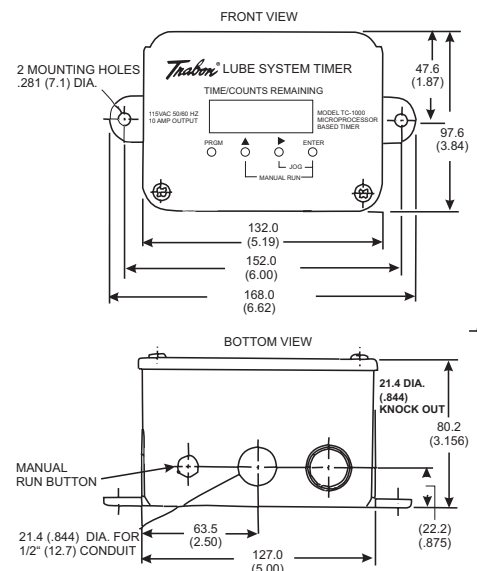

## WIRING INFORMATION

**CAUTION:** INPUT VOLTAGE WILL BE PRESENT ON TERMINAL - 5 FOR DC MODELS ONLY.

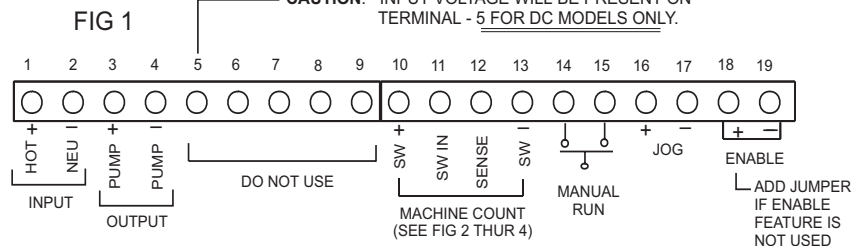

## WIRING INFORMATION con't

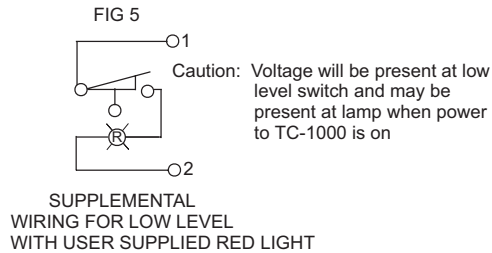
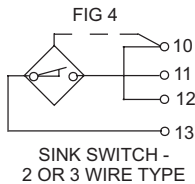
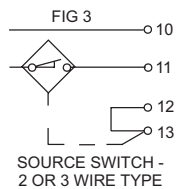
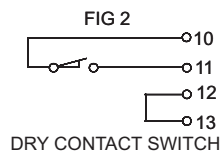

## PROGRAMMING INSTRUCTIONS

### DISPLAYS

The TC-1000 timer has icons in the display to indicate if the unit is in a lube ON cycle or OFF cycle and to show the timing mode. They are also used to indicate which counter is being adjusted when programming new ON and OFF times. The LCD four digit display is used to show the remaining time left in either an ON or OFF cycle, as indicated by the icons. Timing can be set in seconds, minutes, hours or counts. A flashing LCD character indicates that the timer is in the Programming mode.

### PUSH BUTTONS

There are four miniature push buttons used for programming:

PRGM - Program, alternate between setting OFF, ON, or Timer Display

▲ - Increase digit

▶ - Select next digit

ENTER - Enter (save) new setting

### OPERATION

When power is applied, the timer counts down alternately from the programmed ON/OFF times/counts to zero. In the ON TIME mode, the pump is activated and the ON icon lights. The digital display counts down the remaining time/counts for the pump to stay on. When the display reaches 0000, the pump turns off and the OFF icon lights. The display now counts down the remaining time/counts until the next lube application. The timer is programmed to retain the time count in memory when power is turned off. This feature prevents excessive lubrication in start/stop applications.

### CHANGING SETTINGS

In the Timer display mode, pressing the PRGM button will alternately display the SET ON, SET OFF and DISPLAY modes. When the PRGM is pressed the first time, the ON icon will start to blink, indicating the change mode. Pressing

PRGM again will light the OFF icon and display the existing OFF time. Pressing PRGM a third time will return the unit back to the DISPLAY mode, showing the current status of the timer. No digits will blink in the DISPLAY mode.

The values of the timer settings are changed using the PRGM, ENTER and Arrow keys. Pressing the PRGM key scrolls through the three modes: SET ON, SET OFF and RUN (display). In the SET ON and SET OFF modes, the ON and Off icons blink, respectively. No blinking is observed in the RUN mode.

To set a new ON time/count, press the PRGM key until the ON icon begins to blink. The current ON time/count will be displayed. Press the ENTER key. The ON time/count digit will blink. Change the value using the ▲ key and ▶ key. Press ENTER to register the new values. The SEC/MIN/HR/CNT icon will now blink. Press ENTER to accept the time base or the ▲ key to scroll through the timing choices. Press ENTER again to complete the process.

The OFF icon will now be blinking. Repeat the above process to change the OFF setting or press PRGM to return to the RUN/DISPLAY MODE.

**Note:** Scrolling through the modes using the PRGM key only will allow the review of the current settings without changing any of the values.

### MANUAL RUN

A manual-run lubrication cycle may be initiated by pressing the manual run button, located on the left underside of the unit, OR by shorting terminals 14 and 15 together, such as with a remote push-button momentary switch.

### JOG

Pressing the ▶ and ENTER keys simultaneously starts a jog cycle and cancels a lube in process. The timer enters the "PUMP ON" mode for as long as the buttons are depressed. The jog may also be initiated by an external button connected to the terminal strip.

### ENABLE

The enable contacts must be closed for the TC-1000 to function. Open contacts will suspend operation and counting. When contacts are closed, normal operation continues at the point where the Enable has been removed.

## ORDERING INFORMATION

VOLTAGE	PART NUMBER
115 VAC, 50/60hz	163-400-042
230 VAC, 50/60hz	163-400-043
12 VDC	163-400-040
24 VDC	163-400-041

All written and visual data contained in this document are based on the latest product information available at the time of publication. Graco reserves the right to make changes at any time without notice.

Call today for product information or to request a demonstration.

1.800.USA.LUBE (1-800-872-5823) or visit us at [www.lubriquip.graco.com](http://www.lubriquip.graco.com).

©2006 Graco Inc. Bulletin 14530, May 2007. Printed in U.S.A.

All other brand names or marks are used for identification purposes and are trademarks of their respective owners.

