

# Lubrication Systems Multi-Purpose Controller™

## DESCRIPTION

The Lubriquip Multi-Purpose Controller™ (MPC) is a micro-processor based controller designed to operate, monitor, and control all types of centralized lubrication systems. The MPC™ can be used in Series-Progressive, Injector, Piston Distributor, Dual-Line, and Air/Oil types of lubricant distribution systems for scheduling the lubricating cycles and then monitoring for the successful operation of the lube system's pump and distributing devices. It can be used on either a single system or two independent lubrication systems.

Typical applications for the MPC's multi-zone, or systems, capabilities are:

- Part washing machines which have “wet areas” that require either grease or heavy oil lubrication, plus “dry areas” which may require a lower viscosity lubricant. The two separate lube systems may be required to activate on different interval schedules for the application of their individual lubricants.
- Gear-spray applications that require activation and timing control of both the air flow and oil flow components into the air-oil mixing device.
- Drilling & Reaming tool operations that require independent monitoring and control of the air-oil lubrication for each of the successive operations.
- Two-zone lubricant distribution systems that use a common lubricant, reservoir, and pump, but require independent control and scheduling for servicing each zone's lube points.
- Adjacent machine tools that can be more economically lubricated using one two-zone MPC instead of two separate controllers, each dedicated to one machine.
- Machine tools that require independent ways and slides (machine) lube and also air + oil lubrication for high rotating speed components.
- Stamping presses that require both oil and grease lubrication for their rotating and moving components, which therefore require two separate and independent lube systems operating on greatly different lube application schedules.



## DESIGN FEATURES AND BENEFITS

- Controls centralized intermittent lubrication systems with Series-Progressive, Injector, Piston Distributor, Dual-Line, or Air-Oil lubrication systems.
- Reduces controller costs in half when used to monitor and control two or more independent lube systems.
- Half or full cycle programming capability for dual-line systems applications.
- Lube cycle intervals in seconds, minute, hours, days, or counts up to maximums of 100 days or 100,000 counts.
- Spray nozzle air purging (after-blow) capability for gear spray systems.
- Programmable with either the internal 3-button keypad, or externally with the magnetic DataWand or serial port.
- Programming is password protected (user set).
- Programming retained in non-volatile EEPROM during power failures or shutdown.
- Programmable for monitoring of lube cycle completion, over-counts, and low lubricant level.
- Additional parameters of high system pressure, low air pressure, or clogged filter can be monitored with two sets of external fault input terminals available, one in each zone.
- Back-lit display for clear viewing in low ambient light locations.
- System status continuously indicated by 8 LED lights.
- Manual-run capability for facilitating installation, start-up, and troubleshooting activities.
- RS-232 serial communications port.

The MPC indicates the lubrication cycle status with a back-lighted two-line, 16 character alphanumeric Liquid Crystal Display (LCD) and eight high-intensity Light Emitting Diodes (LED). The lighted display and bright LED's allow the operator to determine system status even in poorly lighted areas.

The MPC's NEMA 4X (IP-66) enclosure is constructed of molded polyester fiberglass and is chemical and temperature resistant as well as sealed to prevent intrusion of sprayed or dripping fluids. The LCD and LED displays are easily visible through the large, scratch-resistant Lexan window in the hinged door. The door's two quick-release latches, which can be secured via a latch padlock, offer easy access to the MPC's programming keypad inside. The MPC is also capable of being programmed quickly, without the need to open the door, by using the optional magnetic DataWand and Safety Set, which enable programming to be implemented remotely through the Lexan viewing window. An internal swing panel contains all of the display and logic circuitry and is easily and quickly removable for installation, maintenance, or replacement purposes by removing its two spring-loaded hinge pins and unplugging the ribbon cable connector and ground wire.

The Multi-Purpose Controller is easily programmed at the application site directly, or by downloading an existing program schedule through its RS-232 serial communications port. The RS-232 port enables the user to remotely monitor the status of the MPC, as well as to input the programming parameters.

## DEFINITIONS

**CENTRALIZED LUBRICATION SYSTEM** – total system usually includes (1) a centrally located pump package with a reservoir, pump, and accessory devices; (2) a lubricant distribution system with feed lines, check valves, and proportioning/dispensing devices; and (3) a monitoring and controlling unit that schedules and supervises the lubricating activity for adherence to the Lubrication Program.

**LUBRICATION PROGRAM** – a lubrication schedule established by the lube system designer, according to the machine and/or moving component manufacturer's specifications, to ensure that the lubrication system will deliver the correct amount of lubricant to each designated lube point at the proper intervals.

**PROGRAMMING** – the process of inputting specified lubrication scheduling parameters into the MPC to execute the Lubrication Program specified for each moving/ rotating component on the machine tool to be lubricated.

**PROGRAM (IDLE) PERIOD** – the interval of time or machine operations specified between the end of one lube cycle and the beginning of the next. Programmable in either time or number of machine cycles/operations/strokes.

**MONITOR TIME PERIOD** – a user-determined period of time that specifies the expected maximum amount of time normally necessary for completion of a typical lubrication cycle. Failure to complete the lube cycle within the specified monitor time will cause the MPC to generate a "time out" fault indication.

**CYCLE (LUBE SYSTEM)** – two contact transitions (closed-to-open + open-to-closed) of a cycle switch on a Series-Progressive divider valve assembly, or one contact closure of a pressure switch in an Injector, Piston Distributor, or Dual-Line lube distribution system.

### **MACHINE STROKE/CYCLE BASED**

**PROGRAMMING** – specifying the Program/Idle interval period in number of machine cycles/operations by using an additional external switch as a counter on the machine to provide a signal of its cycling activity to the MPC.

**WATCHDOG TIME** – monitors the machine cycle/stroke input frequency. Failure to receive a full switch contacts' transition input signal from the external switch within a time period designated by the user will generate a fault, prompting the operator to check the "health" of the machine's cycle switch for possible defects. Available as a user-selectable option during programming of the MPC.

**POWER TO PUMP (PULSED/CONTINUOUS)** – user-variable On/Off power duty cycle output to a control device or lubricating system pump. Maximum on and off time of 10 minutes each, enabled and specified by the user during initial MPC programming in accordance with the lubrication system's operating specifications. Reciprocating pump systems would be programmed with some minimum "off" time period to allow for re-priming of the piston pump's output chamber. Electric gear oil pumps would be programmed with the pump output power selected for continuous.

**DEFINITIONS Con't**

**PRE-LUBRICATION (PRE-LUBE) @ POWER-ON**

– When programmed “ON” (enabled), a complete lubrication cycle will occur immediately when power is first applied to the MPC. If this feature is disabled during programming, a complete Program/Idle interval must be completed before a lube cycle is initiated. The pre-lube cycle is most often utilized when machines are idle for lengthy periods of time and its lubricated condition is questionable at start-up.

**ZONE 2** - When enabled during Programming, this feature doubles the number of lubrication systems/zones able to be controlled and monitored by the MPC. Activation of Zone 2 enables lube application to be performed in two separate locations on the same machine, or on adjacent machines, using the same Controller to control either a pump common to both systems, or two separate, i.e. oil and grease, lubricating systems. The two zones can be programmed with greatly different lube cycle requirements which the MPC will accurately schedule and monitor as required. Zone 2 will not be available when one 1 is programmed for use with a dual-line lubricating system.

**OPTIONS**

**Safety Set Kit**

The Safety Set includes a magnetically-sensitive switch bank that plugs into the face of the MPC, enabling programming access and operation of the MPC without requiring the cover to be unlatched and opened. The three switches duplicate the function buttons inside the MPC and are activated with a magnetic DataWand. The switch bank can reset, select, and program, but can also be field-modified to allow only the reset and select functions.

**SPECIFICATIONS**

**Input Power:** ..... 115 VAC; 230 VAC; 24 VDC

**Temperature Range:** .....-4° F to +158° F  
 (-20° C to +70° C)

**Pump Power Outputs (Programmable):**  
 ..... two - one per zone  
 2.0 amperes max. (fused) (continuous or cyclic)  
 Cyclic On-time: 1 second to 10 minutes  
 Cyclic Off-time: 1 second to 10 minutes

**Auxiliary Power Outputs (Non-Programmable):**  
 ..... two - one per zone  
 2.0 amperes max. (fused) - continuous

**Cycle switch inputs:** ..... two - one per zone  
 ½ cycle (1 to 999,999 counts)  
 dry contact, or solid state sourcing/sinking types

**Stroke cycle switch inputs:** ..... two (one per zone)  
 ½ cycle (1 to 999,999 counts)  
 dry contact, or solid state sourcing/sinking types

**Other inputs:**  
 .....low-level - two (1 per zone)  
 ..... external fault - two (1 per zone)  
 (high pressure/low pressure/clogged filter)

**Watchdog time interval range:** ..... 1 second to 1 hour  
 (stroke cycle switch input monitor)

**Lube off time interval range:** ....1 second to 100 days  
 (2 independent settings in seconds, minutes, hours, or days)

**Lube-off stroke interval range:**..... 1 to 999,999  
 machine cycles/counts

**Lube-on cycle count range:**..... 1 to 99 divider  
 valve assembly cycles

**Monitor time period range:** ..... 1 second to 30 hours  
 (2 independent settings in seconds, minutes, or hours)

**Post Lube cycle air purge:** .....1 second to 10 minutes

**Prelube:** ..... User selectable (On or Off)

**Password Protection:** ..... User selected – 4 digits

**Enclosure:** ..... NEMA 4X Polyester fiberglass with  
 clear Lexan cover (IP-66)

**Display:**  
 .....Back-lit, two line, 16 character, annotated LCD

**Indicator lights:** ..... 8 LED's – 4 per zone  
 NORMAL (green); OPERATE (yellow);  
 CYCLE (yellow); and FAULT (red)

**Program entry:** ..... Three-key keypad  
 (Reset/Clear; Select; Program)  
 or via RS-232 serial port

**Manual Run:** .....Keypad push-button or DataWand

**RS-232 Port:** .....Read status, write setpoints  
 using auxiliary/remote terminal

## ORDERING INFORMATION

Description	Part Number
MPC – 115 VAC/24VDC.....	163-310-044
MPC – 230 VAC/24VDC.....	163-310-045
MPC – 24 VDC [CE marked version].....	163-310-046*
Swing-Out Panel Assembly with Logic module/LCD/Ribbon Cable .....	492-030-051
Power Board for 115 VAC/24 VDC MPC .....	572-144-666
Power Board for 230 VAC/24 VDC MPC.....	572-144-670
*Power Board for 24 VDC MPC.....	572-144-671
Relay Board w/o relays for all models .....	572-144-667
115 VAC/230 VAC Output Relay .....	570-999-983
24 VDC Output Relay.....	570-999-984
Ribbon Cable	
Power Board to Relay board.....	572-144-668
Safety Set.....	560-002-011
Data Wand only.....	560-002-580

\* Available at future date – consult factory

## DIMENSIONS Inches (mm)

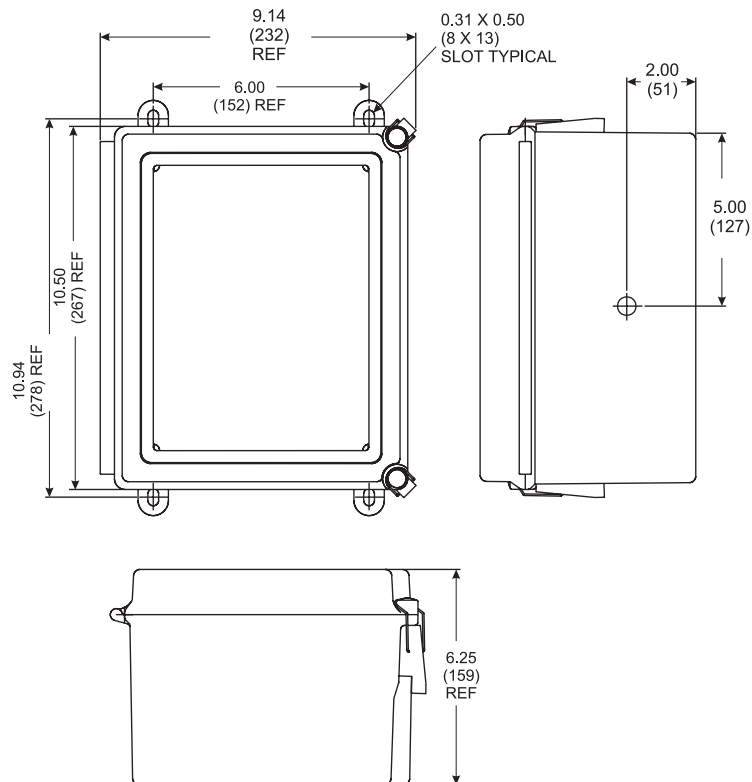

All written and visual data contained in this document are based on the latest product information available at the time of publication. Graco reserves the right to make changes at any time without notice.

Call today for product information or to request a demonstration.

**1.800.USA.LUBE** (1-800-872-5823) or visit us at [www.lubriquip.graco.com](http://www.lubriquip.graco.com).

©2006 Graco Inc. Bulletin 14760, October 2003. Printed in U.S.A.

All other brand names or marks are used for identification purposes and are trademarks of their respective owners.

